



PRICE LIST 09/2024-WW-A.5  
INSERTS FOR EUROMAC MULTITOOLS

# PRICE LIST 09/2024-WW-A.5



## VALIDITY OF PRICES:

This price list is valid from 01.09.2024. From this date old price lists lose their validity. The prices do not include statutory value added tax.

## CONDITIONS OF PAYMENT:

Unless otherwise stipulated, our invoices are payable in full 30 days after the submission of the invoice.

## SCOPE OF APPLICATION:

Deliveries and services provided by PASS Stanztechnik AG are effected exclusively according to PASS delivery and payment conditions. These conditions shall be deemed accepted at the latest upon receipt of the goods or services.

## GENERAL REMARKS:

You can find our general terms and conditions on our Homepage under: [www.pass-ag.com](http://www.pass-ag.com)

## INSERTS FOR EUROMAC MULTITOOLS

|  |         |
|--|---------|
| XMTE10-12,7; FMTE10-12,7 .....                 | page 6  |
| XMTE6-24; XMTE10-24; FMTE6-24; FMTE10-24 ..... | Seite 7 |
| XMTE4-31,75; FMTE4-31,75 .....                 | page 8  |

## OPTIONS

|                      |         |
|----------------------|---------|
| Draw-polishing ..... | page 12 |
|----------------------|---------|

## SPECIAL SHAPES

|                                   |         |
|-----------------------------------|---------|
| O.D. Ground Special Shapes.....   | page 16 |
| EDM Required Special Shapes ..... | page 17 |



# INSERTS FOR EUROMAC MULTITOOLS

PASS TOOLS FOR YOUR EUROMAC MULTITOOL SYSTEM

## INDEX

|  |        |
|--|--------|
| XMTE10-12,7; FMTE10-12,7                 | page 6 |
| XMTE6-24; XMTE10-24; FMTE6-24; FMTE10-24 | page 7 |
| XMTE4-31,75; FMTE4-31,75                 | page 8 |

# EUROMAC

XMTE10-12,7; FMTE10-12,7

PUNCH RIGID

PUNCH ADJUSTABLE

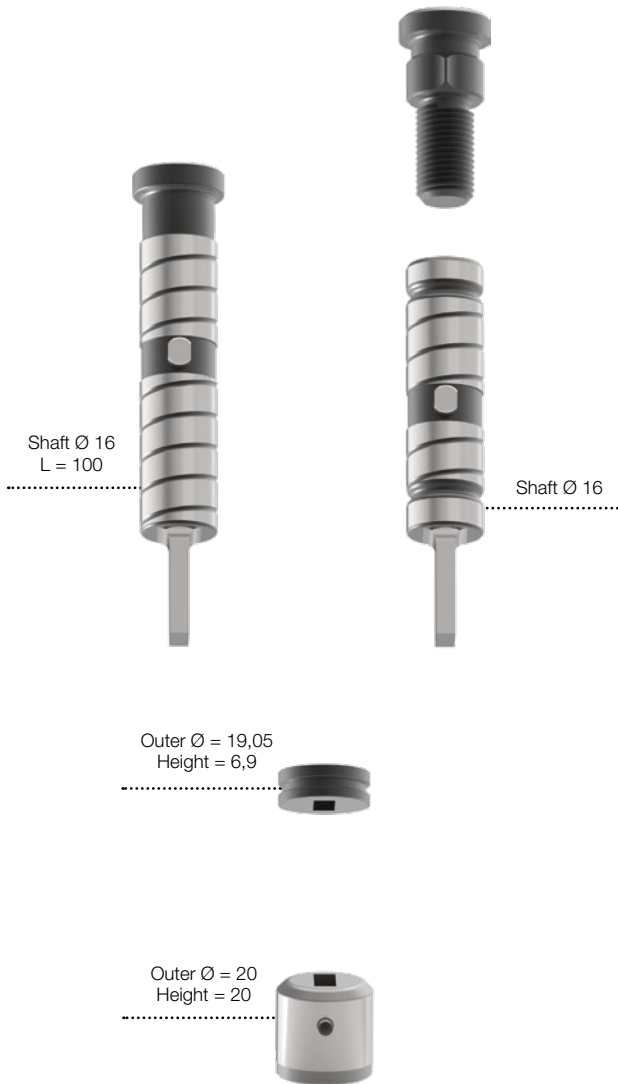

|                                   | PART-NO.  | PRICE IN € |
|-----------------------------------|-----------|------------|
| <b>PUNCH - RIGID (H-PM®)</b>      |           |            |
| Round                             | 413101    | 36,97      |
| Square                            | 413102    | 72,65      |
| Rectangle                         | 413103    | 72,65      |
| Oblong                            | 413104    | 72,65      |
| O.D. Ground Special Shape         | 41310G    | 89,19      |
| EDM Required Special Shape        | 41310E    | 112,10     |
| <b>PUNCH - ADJUSTABLE (H-PM®)</b> |           |            |
| Punch head                        | 1999X1791 | 28,03      |
| Round                             | 413101-A  | 36,97      |
| Square                            | 413102-A  | 72,65      |
| Rectangle                         | 413103-A  | 72,65      |
| Oblong                            | 413104-A  | 72,65      |
| O.D. Ground Special Shape         | 41310G-A  | 89,19      |
| EDM Required Special Shape        | 41310E-A  | 112,10     |
| <b>STRIPPER</b>                   |           |            |
| Round                             | 415101    | 42,08      |
| Square                            | 415102    | 75,20      |
| Rectangle                         | 415103    | 75,20      |
| Oblong                            | 415104    | 75,20      |
| O.D. Ground Special Shape         | 41510G    | 94,27      |
| EDM Required Special Shape        | 41510E    | 100,68     |
| <b>DIE (HWS)</b>                  |           |            |
| Round                             | 414101    | 36,97      |
| Square                            | 414102    | 62,46      |
| Rectangle                         | 414103    | 62,46      |
| Oblong                            | 414104    | 62,46      |
| O.D. Ground Special Shape         | 41410G    | 78,98      |
| EDM Required Special Shape        | 41410E    | 85,38      |

| PUNCH OPTIONS  |        | DIE OPTIONS         |       |
|--|--------|---------------------|-------|
| TICN coating (working with stainless steel)            | 31,07  | Reinforced die      | 19,89 |
| T-MAX coating (working with galvanised sheet / zincor) | 54,69  | H-PM® Quality       | 8,95  |
| A-MAX coating (working with aluminum)                  | 45,99  | Additional pin hole | 16,17 |
| WT-shear (whisper shear)                               | 18,64  |                     |       |
| DOWT-shear (rooftop shear)                             | 18,64  |                     |       |
| 2 PT-shear (inverted rooftop shear)                    | 22,38  |                     |       |
| 4 PT-shear (inverted cross shear)                      | 27,33  |                     |       |
| Cutting part under 1,00 mm                             | + 40 % |                     |       |

|                                   | PART-NO.  | PRICE IN € |
|-----------------------------------|-----------|------------|
| <b>PUNCH - RIGID (H-PM®)</b>      |           |            |
| Round                             | 413041    | 36,97      |
| Square                            | 413042    | 72,65      |
| Rectangle                         | 413043    | 72,65      |
| Oblong                            | 413044    | 72,65      |
| O.D. Ground Special Shape         | 41304G    | 89,19      |
| EDM Required Special Shape        | 41304E    | 112,10     |
| <b>PUNCH - ADJUSTABLE (H-PM®)</b> |           |            |
| Punch head                        | 1999X1691 | 28,03      |
| Round                             | 413041-A  | 36,97      |
| Square                            | 413042-A  | 72,65      |
| Rectangle                         | 413043-A  | 72,65      |
| Oblong                            | 413044-A  | 72,65      |
| O.D. Ground Special Shape         | 41304G-A  | 89,19      |
| EDM Required Special Shape        | 41304E-A  | 112,10     |
| <b>STRIPPER</b>                   |           |            |
| Round                             | 415041    | 54,70      |
| Square                            | 415042    | 75,20      |
| Rectangle                         | 415043    | 75,20      |
| Oblong                            | 415044    | 75,20      |
| O.D. Ground Special Shape         | 41504G    | 94,27      |
| EDM Required Special Shape        | 41504E    | 100,68     |
| <b>DIE (HWS)</b>                  |           |            |
| Round                             | 414041    | 40,67      |
| Square                            | 414042    | 62,46      |
| Rectangle                         | 414043    | 62,46      |
| Oblong                            | 414044    | 62,46      |
| O.D. Ground Special Shape         | 41404G    | 78,98      |
| EDM Required Special Shape        | 41404E    | 85,38      |

PUNCH RIGID

PUNCH ADJUSTABLE

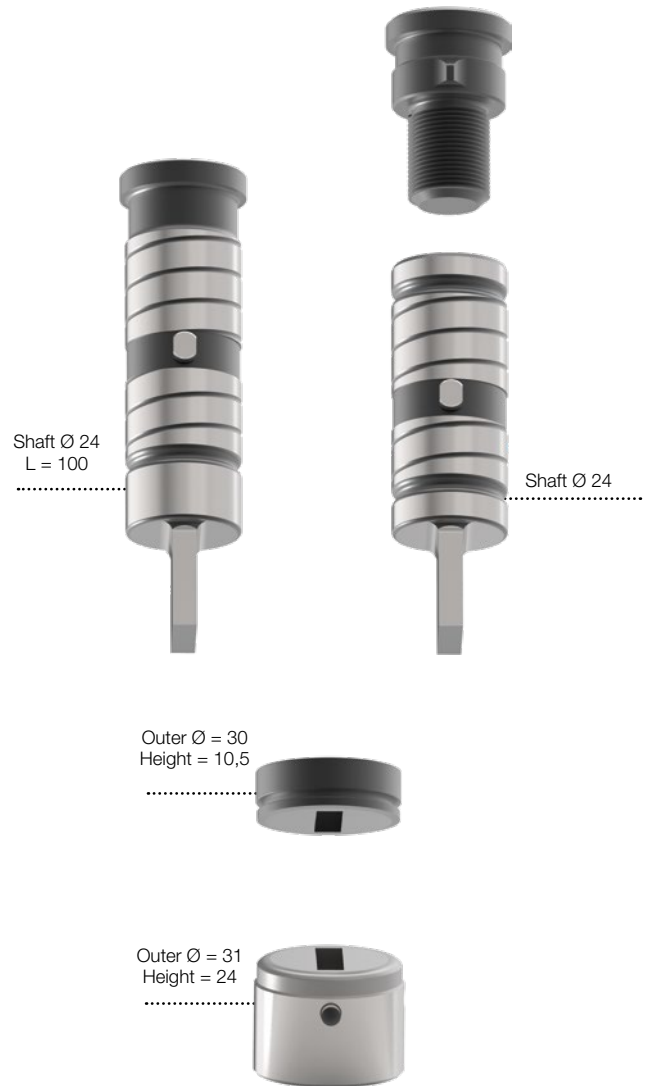

| PUNCH OPTIONS  | PRICE  | DIE OPTIONS         | PRICE |
|--|--------|---------------------|-------|
| TICN coating (working with stainless steel)            | 31,07  | Reinforced die      | 19,89 |
| T-MAX coating (working with galvanised sheet / zincor) | 54,69  | H-PM® Quality       | 8,95  |
| A-MAX coating (working with aluminum)                  | 45,99  | Additional pin hole | 16,17 |
| WT-shear (whisper shear)                               | 18,64  |                     |       |
| DOWT-shear (rooftop shear)                             | 18,64  |                     |       |
| 2 PT-shear (inverted rooftop shear)                    | 22,38  |                     |       |
| 4 PT-shear (inverted cross shear)                      | 27,33  |                     |       |
| Cutting part under 1,00 mm                             | + 40 % |                     |       |

# EUROMAC

XMTE4-31,75; FMTE4-31,75



|                      |                            | PART-NO. | PRICE IN € |
|----------------------|----------------------------|----------|------------|
| <b>PUNCH (H-PM®)</b> |                            |          |            |
|                      | Round                      | 413141   | 67,55      |
|                      | Square                     | 413142   | 107,01     |
|                      | Rectangle                  | 413143   | 107,01     |
|                      | Oblong                     | 413144   | 107,01     |
|                      | O.D. Ground Special Shape  | 41314G   | 127,41     |
|                      | EDM Required Special Shape | 41314E   | 281,59     |
| <b>STRIPPER</b>      |                            |          |            |
|                      | Round                      | 415141   | 31,88      |
|                      | Square                     | 415142   | 59,91      |
|                      | Rectangle                  | 415143   | 59,91      |
|                      | Oblong                     | 415144   | 59,91      |
|                      | O.D. Ground Special Shape  | 41514G   | 67,55      |
|                      | EDM Required Special Shape | 41514E   | 73,88      |
| <b>DIE (HWS)</b>     |                            |          |            |
|                      | Round                      | 414141   | 27,33      |
|                      | Square                     | 414142   | 65,02      |
|                      | Rectangle                  | 414143   | 65,02      |
|                      | Oblong                     | 414144   | 65,02      |
|                      | O.D. Ground Special Shape  | 41414G   | 78,98      |
|                      | EDM Required Special Shape | 41414E   | 85,38      |

| PUNCH OPTIONS  |        | DIE OPTIONS         |       |
|--|--------|---------------------|-------|
| TICN coating (working with stainless steel)            | 49,71  | Reinforced die      | 8,69  |
| T-MAX coating (working with galvanised sheet / zincor) | 84,51  | H-PM® Quality       | 8,95  |
| A-MAX coating (working with aluminum)                  | 74,57  | Additional pin hole | 16,17 |
| WT-shear (whisper shear)                               | 18,64  |                     |       |
| DOWT-shear (rooftop shear)                             | 18,64  |                     |       |
| 2 PT-shear (inverted rooftop shear)                    | 22,38  |                     |       |
| 4 PT-shear (inverted cross shear)                      | 27,33  |                     |       |
| Cutting part under 1,00 mm                             | + 40 % |                     |       |



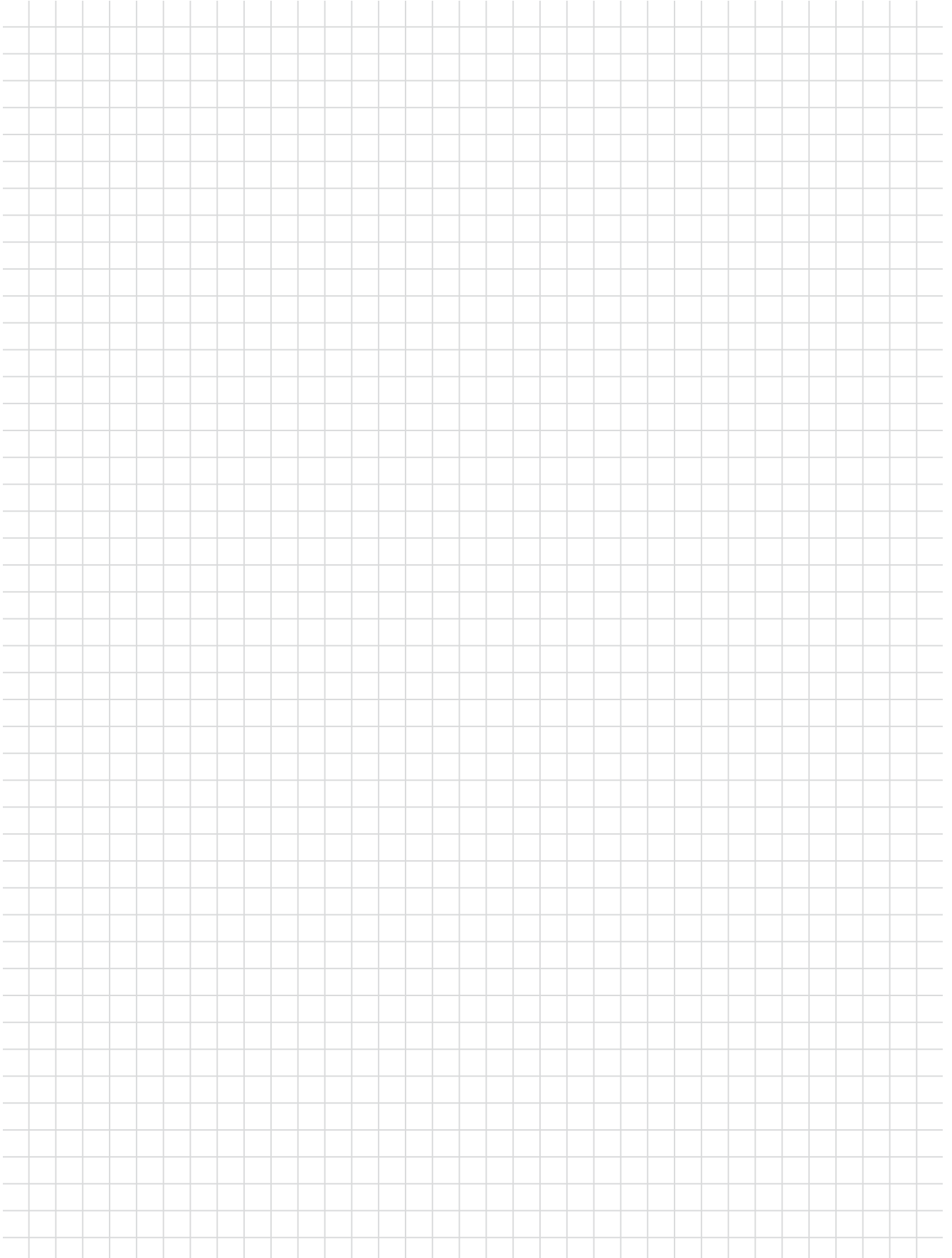

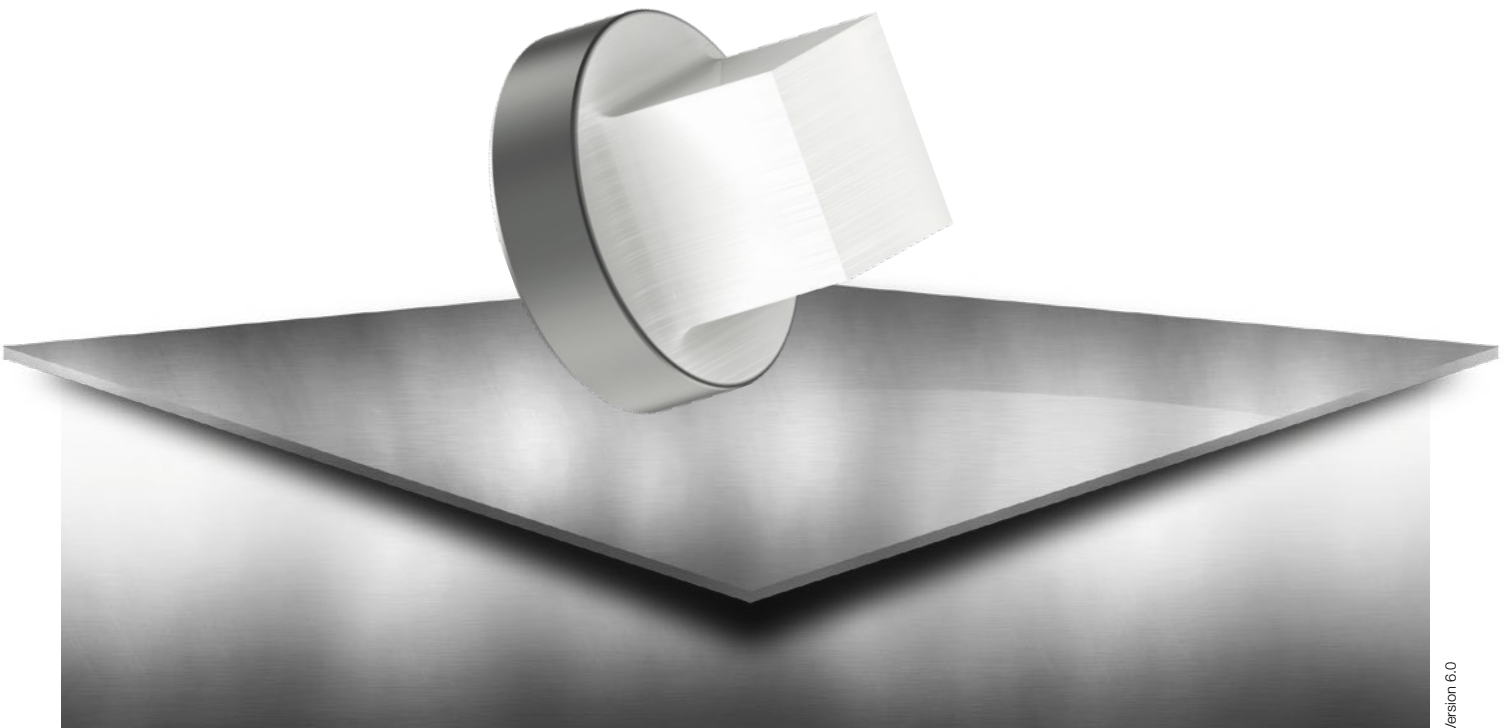

# OPTIONS

PASS OPTIONS FOR YOUR EUROMAC MULTITOOL SYSTEM

## INDEX

Draw-polishing

page 12

# DRAW-POLISHING

## PUNCH EDGES

INCREASES TOOL LIFETIME, REDUCES MATERIAL BUILD UP

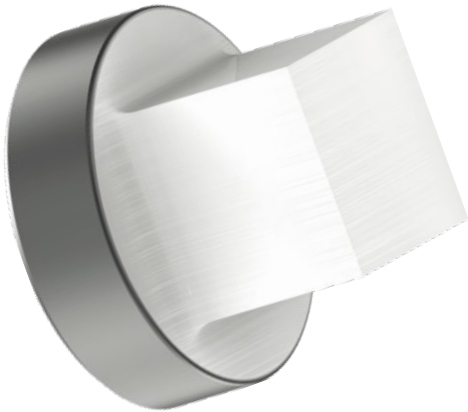

| SIZE  | RANGE              | EXTRA CHARGE IN € |
|---|--------------------|-------------------|
| ROUND / SQUARE / RECTANGLE / OBLONG                     | for all multitools | 21,12             |
| O.D. GROUND SPECIAL SHAPES (SPECIAL SHAPE GROUP 1 & 2)  | for all multitools | 21,12             |
| EDM REQUIRED SPECIAL SHAPES (SPECIAL SHAPE GROUP 3 & 4) | for all multitools | 94,46             |

A large grid of graph paper for taking notes, consisting of 20 columns and 40 rows of small squares.



# SPECIAL SHAPES

PASS SPECIAL SHAPES FOR YOUR EUROMAC  
MULTITOOL SYSTEM

## INDEX

|                             |         |
|-----------------------------|---------|
| O.D. Ground Special Shapes  | page 16 |
| EDM Required Special Shapes | page 17 |

# O.D. GROUND SPECIAL SHAPES

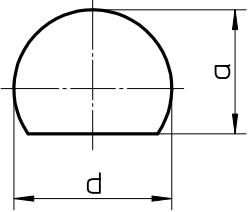
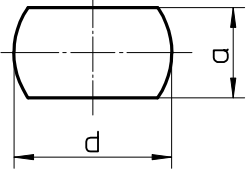
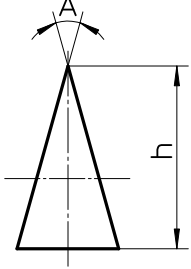
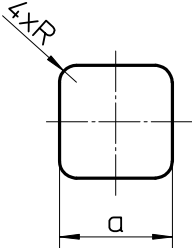
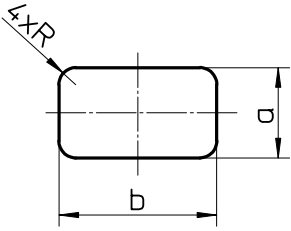
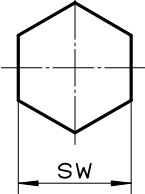
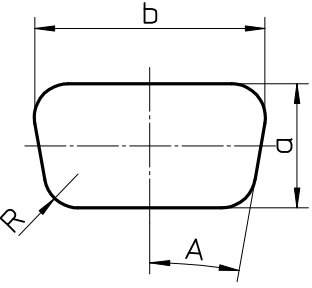
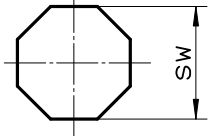
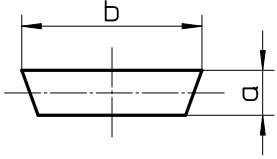
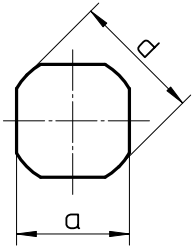
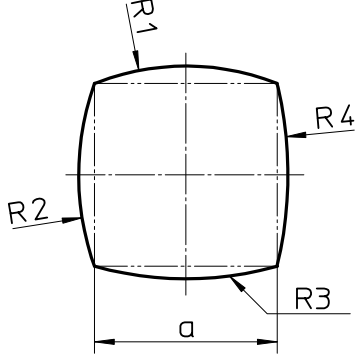
|  |  |  |
|--|--|--|
|  <p>G01</p>   |  <p>G02</p>   |  <p>G03</p>   |
|  <p>G04</p>  |  <p>G05</p>  |  <p>G06</p>  |
|  <p>G07</p> |  <p>G08</p> |  <p>G09</p> |
|  <p>G10</p> |  <p>G11</p> |  |

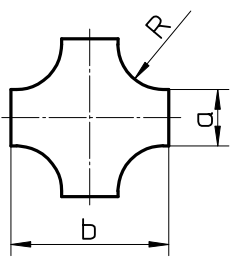
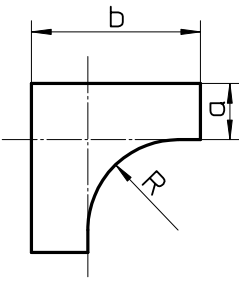
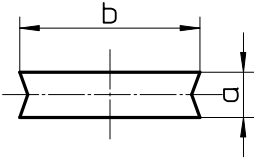
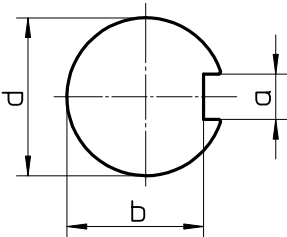
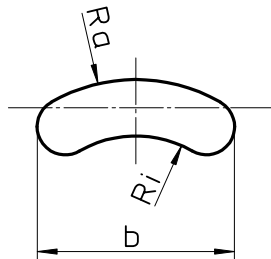
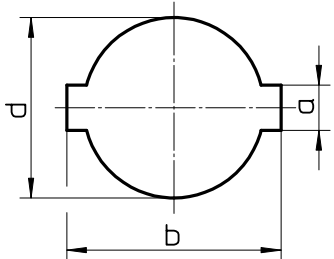
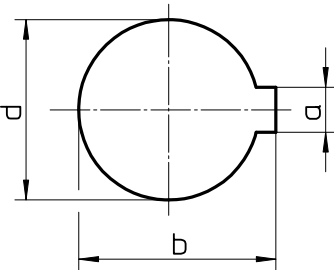
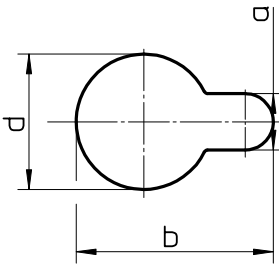
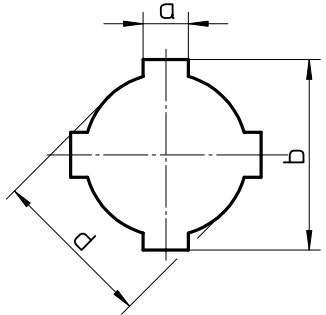
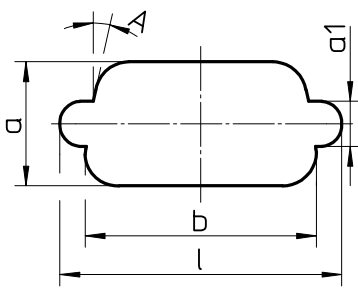
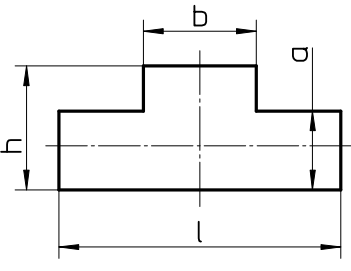

# EDM REQUIRED SPECIAL SHAPES

|  |  |  |
|--|--|--|
|  <p>E01</p>   |  <p>E02</p>   |  <p>E03</p>   |
|  <p>E04</p>  |  <p>E05</p>  |  <p>E06</p>  |
|  <p>E07</p> |  <p>E08</p> |  <p>E09</p> |
|  <p>E10</p> |  <p>E11</p> |  |

# NOTES

A large grid of graph paper for taking notes, consisting of 20 columns and 40 rows of small squares.

A large grid of graph paper for taking notes, consisting of 20 columns and 40 rows of small squares.

**SALVAGNINI** | **THICK TURRET** | **TRUMPF**



Am Steinkreuz 2  
95473 Creußen | Germany

**WEB:** [www.pass-ag.com](http://www.pass-ag.com)  
**MAIL:** [info@pass-ag.com](mailto:info@pass-ag.com)

**FON:** +49 (0) 92 70 / 9 85 - 0  
**FAX:** +49 (0) 92 70 / 9 85 - 99