



CATALOG 09/2024-WW-A.5
INSERTS FOR EUROMAC MULTITOOLS



SCOPE OF APPLICATION:

Deliveries and services provided by PASS Stanztechnik AG are effected exclusively according to PASS delivery and payment conditions. These conditions shall be deemed accepted at the latest upon receipt of the goods or services.

GENERAL REMARKS:

You can find our general terms and conditions on our Homepage under: www.pass-ag.com

INSERTS FOR EUROMAC MULTITOOLS

XMTE10-12,7; FMTE10-12,7	page 6
XMTE6-24; XMTE10-24; FMTE6-24; FMTE10-24	Seite 7
XMTE4-31,75; FMTE4-31,75	page 8

OPTIONS

Draw-polishing	page 12
----------------------	---------

SPECIAL SHAPES

O.D. Ground Special Shapes.....	page 16
EDM Required Special Shapes	page 17



INSERTS FOR EUROMAC MULTITOOLS

PASS TOOLS FOR YOUR EUROMAC MULTITOOL SYSTEM

INDEX

XMTE10-12,7; FMTE10-12,7	page 6
XMTE6-24; XMTE10-24; FMTE6-24; FMTE10-24	page 7
XMTE4-31,75; FMTE4-31,75	page 8

EUROMAC

XMTE10-12,7; FMTE10-12,7

PUNCH RIGID

PUNCH ADJUSTABLE

PART-NO.

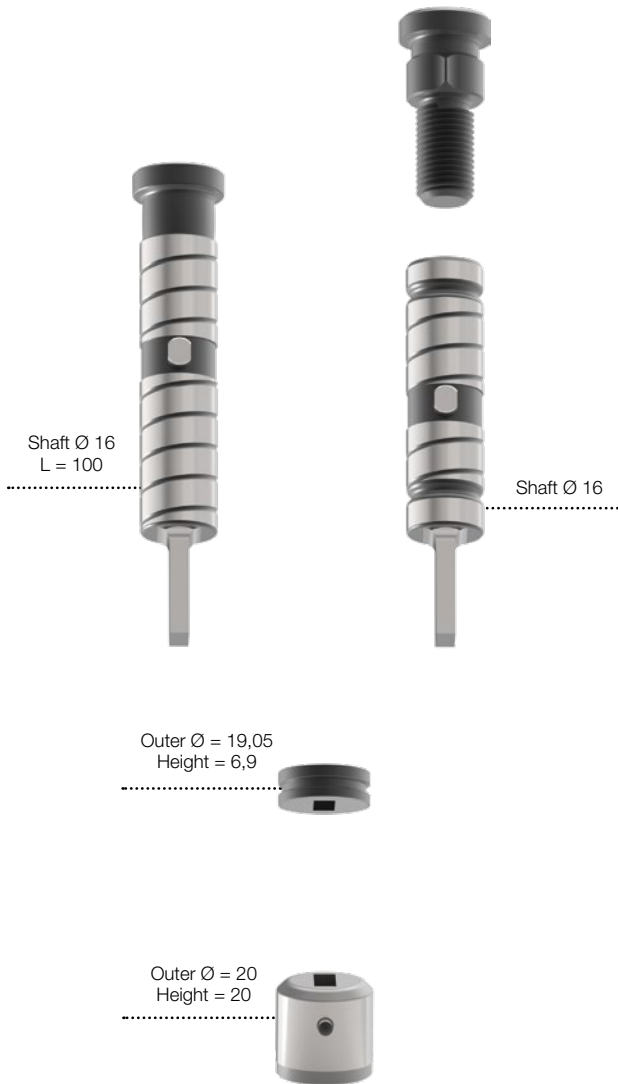

PUNCH - RIGID (H-PM®)		PART-NO.
Round		413101
Square		413102
Rectangle		413103
Oblong		413104
O.D. Ground Special Shape		41310G
EDM Required Special Shape		41310E

PUNCH - ADJUSTABLE (H-PM®)		PART-NO.
Punch head		1999X1791
Round		413101-A
Square		413102-A
Rectangle		413103-A
Oblong		413104-A
O.D. Ground Special Shape		41310G-A
EDM Required Special Shape		41310E-A

STRIPPER		PART-NO.
Round		415101
Square		415102
Rectangle		415103
Oblong		415104
O.D. Ground Special Shape		41510G
EDM Required Special Shape		41510E

DIE (HWS)		PART-NO.
Round		414101
Square		414102
Rectangle		414103
Oblong		414104
O.D. Ground Special Shape		41410G
EDM Required Special Shape		41410E

PUNCH OPTIONS

- TICN coating (working with stainless steel)
- T-MAX coating (working with galvanised sheet / zincor)
- A-MAX coating (working with aluminum)
- WT-shear (whisper shear)
- DOWT-shear (rooftop shear)
- 2 PT-shear (inverted rooftop shear)
- 4 PT-shear (inverted cross shear)
- Cutting part under 1,00 mm

DIE OPTIONS

- Reinforced die
- H-PM® Quality
- Additional pin hole

	PART-NO.
PUNCH - RIGID (H-PM®)	
Round	413041
Square	413042
Rectangle	413043
Oblong	413044
O.D. Ground Special Shape	41304G
EDM Required Special Shape	41304E
PUNCH - ADJUSTABLE (H-PM®)	
Punch head	1999X1691
Round	413041-A
Square	413042-A
Rectangle	413043-A
Oblong	413044-A
O.D. Ground Special Shape	41304G-A
EDM Required Special Shape	41304E-A
STRIPPER	
Round	415041
Square	415042
Rectangle	415043
Oblong	415044
O.D. Ground Special Shape	41504G
EDM Required Special Shape	41504E
DIE (HWS)	
Round	414041
Square	414042
Rectangle	414043
Oblong	414044
O.D. Ground Special Shape	41404G
EDM Required Special Shape	41404E

PUNCH RIGID

PUNCH ADJUSTABLE

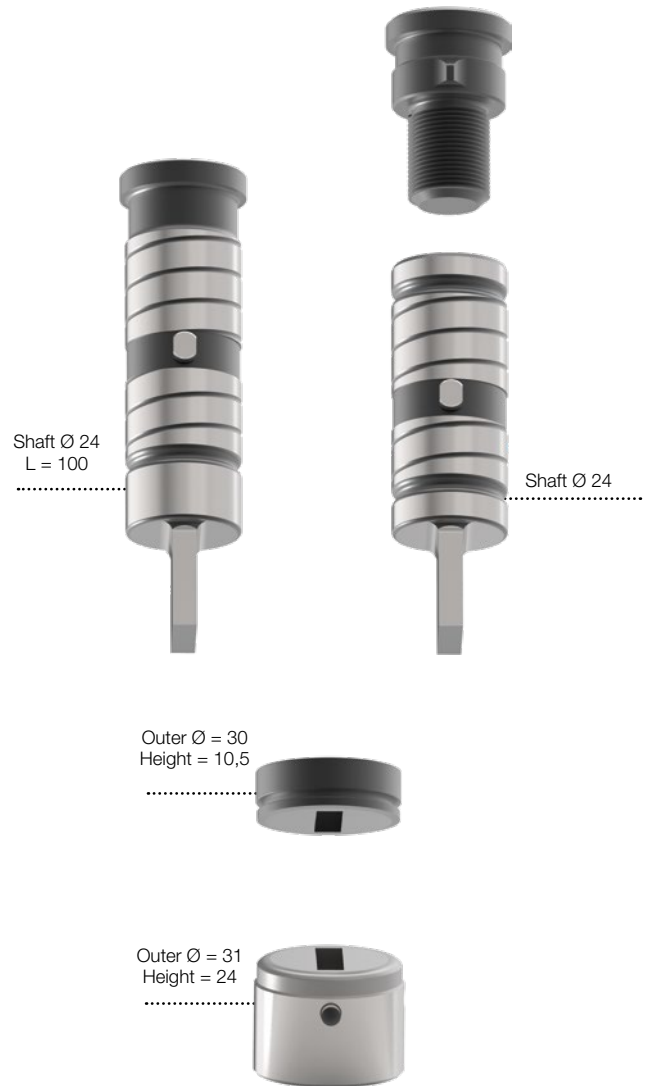

PUNCH OPTIONS

- TICN coating (working with stainless steel)
- T-MAX coating (working with galvanised sheet / zincor)
- A-MAX coating (working with aluminum)
- WT-shear (whisper shear)
- DOWT-shear (rooftop shear)
- 2 PT-shear (inverted rooftop shear)
- 4 PT-shear (inverted cross shear)
- Cutting part under 1,00 mm

DIE OPTIONS

- Reinforced die
- H-PM® Quality
- Additional pin hole

EUROMAC

XMTE4-31,75; FMTE4-31,75



		PART-NO.
PUNCH (H-PM®)		
	Round	413141
	Square	413142
	Rectangle	413143
	Oblong	413144
	O.D. Ground Special Shape	41314G
	EDM Required Special Shape	41314E
STRIPPER		
	Round	415141
	Square	415142
	Rectangle	415143
	Oblong	415144
	O.D. Ground Special Shape	41514G
	EDM Required Special Shape	41514E
DIE (HWS)		
	Round	414141
	Square	414142
	Rectangle	414143
	Oblong	414144
	O.D. Ground Special Shape	41414G
	EDM Required Special Shape	41414E

PUNCH OPTIONS

- TICN coating (working with stainless steel)
- T-MAX coating (working with galvanised sheet / zincor)
- A-MAX coating (working with aluminum)
- WT-shear (whisper shear)
- DOWT-shear (rooftop shear)
- 2 PT-shear (inverted rooftop shear)
- 4 PT-shear (inverted cross shear)
- Cutting part under 1,00 mm

DIE OPTIONS

- Reinforced die
- H-PM® Quality
- Additional pin hole

A large grid of graph paper for taking notes, consisting of 20 columns and 40 rows of small squares.

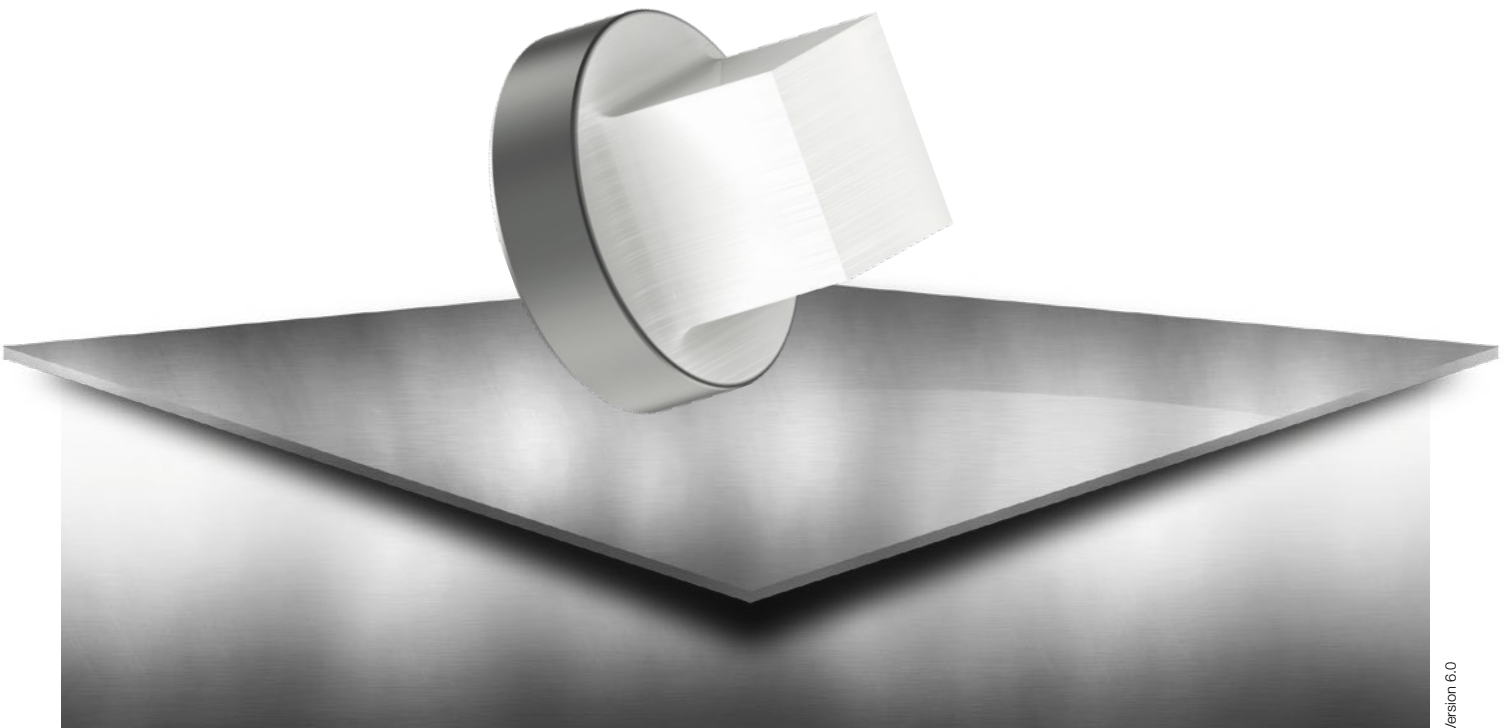

OPTIONS

PASS OPTIONS FOR YOUR EUROMAC MULTITOOL SYSTEM

INDEX

Draw-polishing

page 12

DRAW-POLISHING

PUNCH EDGES

INCREASES TOOL LIFETIME, REDUCES MATERIAL BUILD UP



SIZE	RANGE
ROUND / SQUARE / RECTANGLE / OBLONG	for all multitools
O.D. GROUND SPECIAL SHAPES (SPECIAL SHAPE GROUP 1 & 2)	for all multitools
EDM REQUIRED SPECIAL SHAPES (SPECIAL SHAPE GROUP 3 & 4)	for all multitools

A large grid of graph paper for taking notes, consisting of 20 columns and 40 rows of small squares.



SPECIAL SHAPES

PASS SPECIAL SHAPES FOR YOUR EUROMAC
MULTITOOL SYSTEM

INDEX

O.D. Ground Special Shapes	page 16
EDM Required Special Shapes	page 17

O.D. GROUND SPECIAL SHAPES

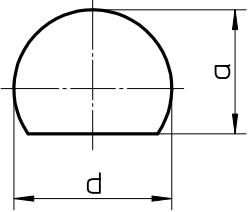
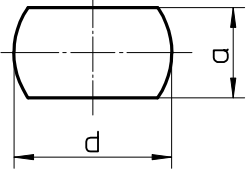
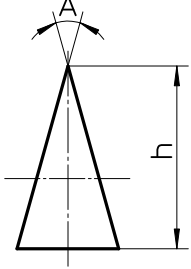
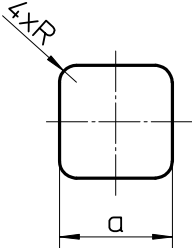
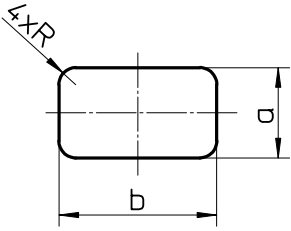
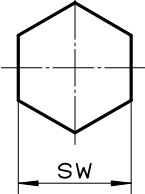
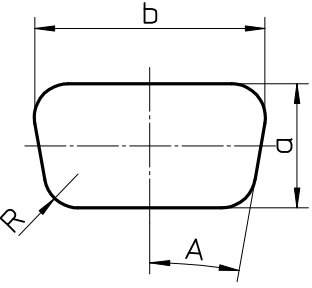
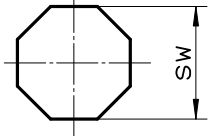
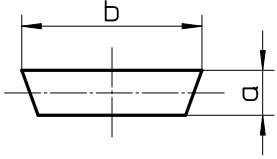
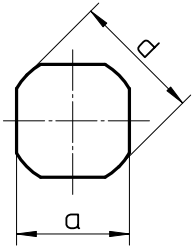
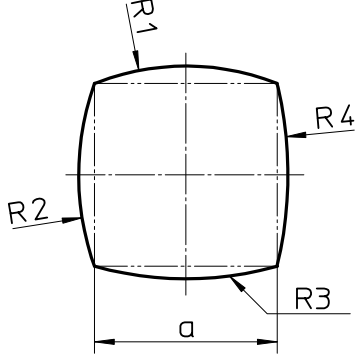
 <p>G01</p>	 <p>G02</p>	 <p>G03</p>
 <p>G04</p>	 <p>G05</p>	 <p>G06</p>
 <p>G07</p>	 <p>G08</p>	 <p>G09</p>
 <p>G10</p>	 <p>G11</p>	

EDM REQUIRED SPECIAL SHAPES

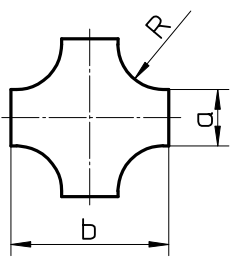
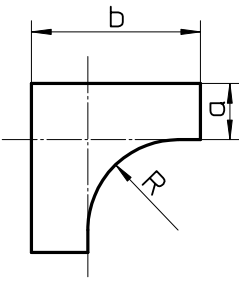
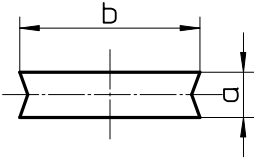
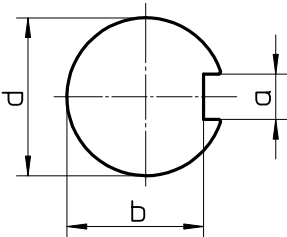
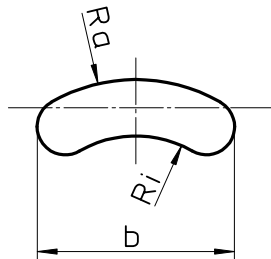
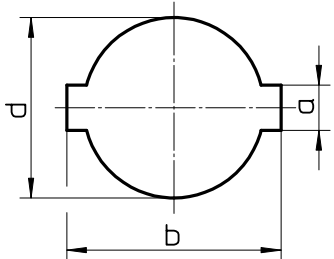
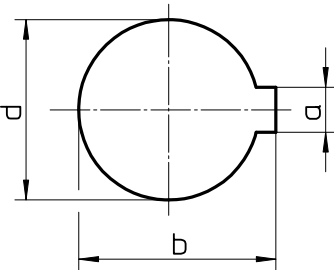
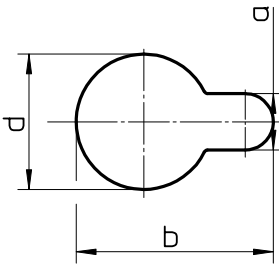
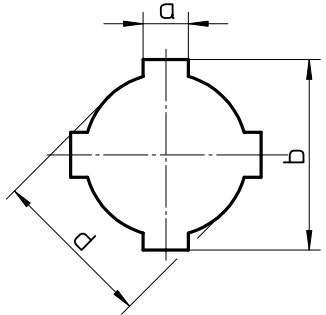
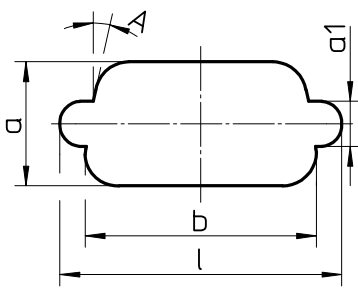
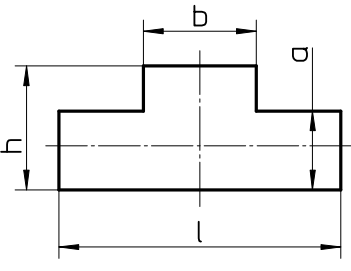
 <p>E01</p>	 <p>E02</p>	 <p>E03</p>
 <p>E04</p>	 <p>E05</p>	 <p>E06</p>
 <p>E07</p>	 <p>E08</p>	 <p>E09</p>
 <p>E10</p>	 <p>E11</p>	

NOTES

A large grid of graph paper for taking notes, consisting of 20 columns and 30 rows of small squares.

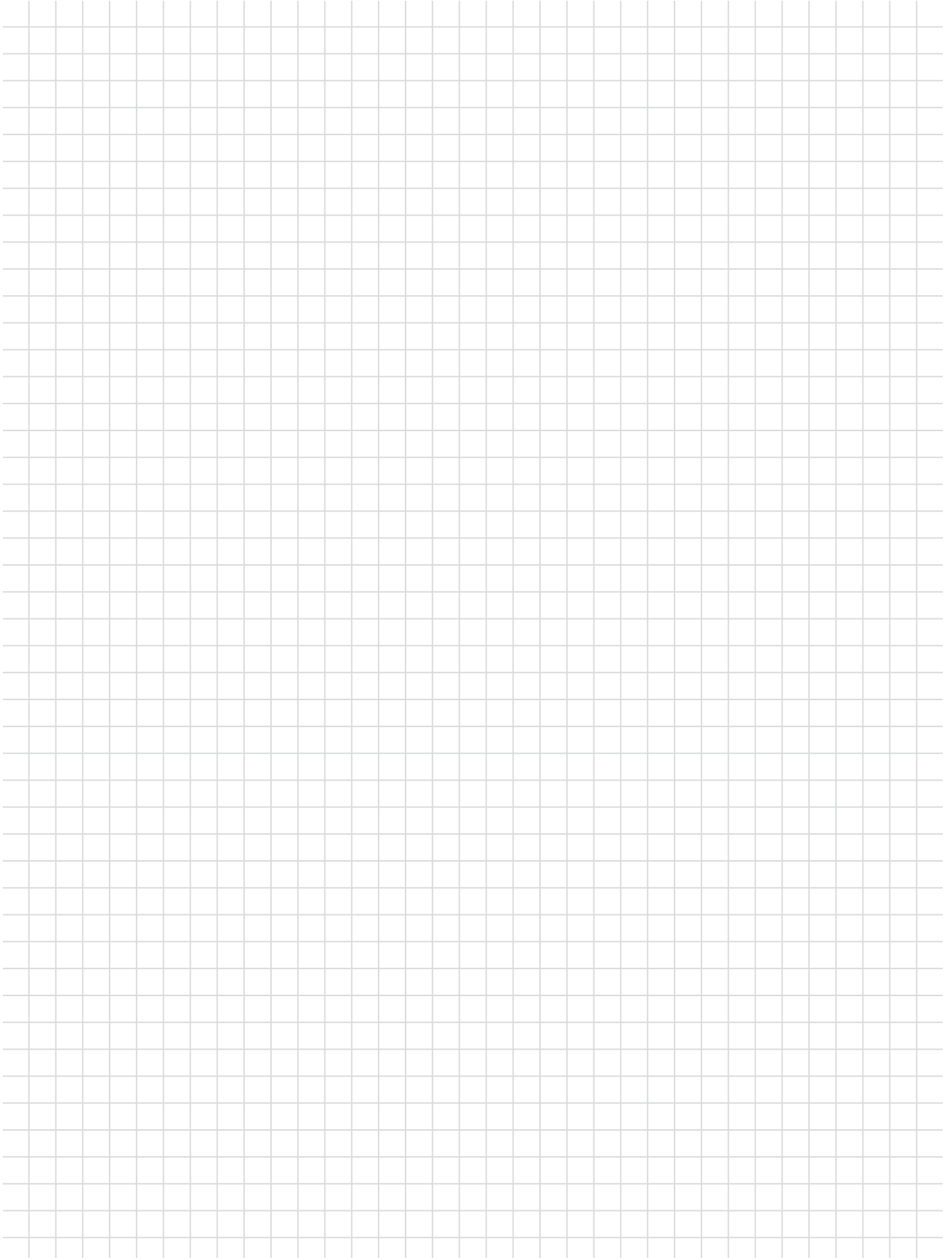

SALVAGNINI | **THICK TURRET** | **TRUMPF**



Am Steinkreuz 2
95473 Creußen | Germany

WEB: www.pass-ag.com
MAIL: info@pass-ag.com

FON: +49 (0) 92 70 / 9 85 - 0
FAX: +49 (0) 92 70 / 9 85 - 99