



CATALOG 09/2024-WW-A.4
INSERTS FOR PRIMA POWER/MULTITOOLS



SCOPE OF APPLICATION:

Deliveries and services provided by PASS Stanztechnik AG are effected exclusively according to PASS delivery and payment conditions. These conditions shall be deemed accepted at the latest upon receipt of the goods or services.

GENERAL REMARKS:

You can find our general terms and conditions on our Homepage under: www.pass-ag.com

INSERTS FOR PRIMA POWER/MULTITOOLS

MTPi24-8; MTP16-8; MT24-8; MTH16-8	page 6
MTPi10-16; MTP8-16; MT10-16; MTH16-16	page 7
MTPi8-24; MTP5-24; MT8-24	page 8
MT3Ri-31,75; MT3i-31,75.....	page 9
MT20i-8.....	page 10
MT8Ri2-16 (Version 2).....	page 11

OPTIONS

Draw-polishing	page 14
----------------------	---------

SPECIAL SHAPES

O.D. Ground Special Shapes.....	page 18
EDM Required Special Shapes	page 19



INSERTS FOR PRIMA POWER/ MULTITOOLS

PASS TOOLS FOR YOUR
PRIMA POWER/MULTITOOL SYSTEM

INDEX

MTPi24-8; MTP16-8; MT24-8; MTH16-8	page 6
MTPi10-16; MTP8-16; MT10-16; MTH16-16	page 7
MTPi8-24; MTP5-24; MT8-24	page 8
MT3Ri-31,75; MT3i-31,75	page 9
MT20i-8	page 10
MT8Ri2-16 (Version 2)	page 11

PRIMA POWER

MTPi24-8; MTP16-8; MT24-8; MTH16-8

PART-NO.

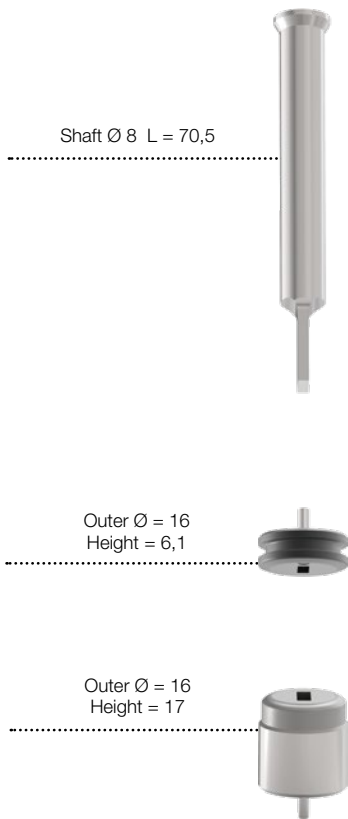

PUNCH (H-PM®)		PART-NO.
Round		413121
Square		413122
Rectangle		413123
Oblong		413124
O.D. Ground Special Shape		41312G
EDM Required Special Shape		41312E

STRIPPER		PART-NO.
Round		415121
Square		415122
Rectangle		415123
Oblong		415124
O.D. Ground Special Shape		41512G
EDM Required Special Shape		41512E

DIE (HWS)		PART-NO.
Round		414121
Square		414122
Rectangle		414123
Oblong		414124
O.D. Ground Special Shape		41412G
EDM Required Special Shape		41412E

PUNCH OPTIONS

- TICN coating (working with stainless steel)
- T-MAX coating (working with galvanised sheet / zincor)
- A-MAX coating (working with aluminum)
- WT-shear (whisper shear)
- DOWT-shear (rooftop shear)
- 2 PT-shear (inverted rooftop shear)
- 4 PT-shear (inverted cross shear)
- Cutting part under 1,00 mm

DIE OPTIONS

- Reinforced die
- H-PM® Quality
- Additional pin hole

PRIMA POWER

MTPi10-16; MTP8-16; MT10-16; MTH16-16

	PART-NO.
PUNCH (H-PM®)	
Round	413021
Square	413022
Rectangle	413023
Oblong	413024
O.D. Ground Special Shape	41302G
EDM Required Special Shape	41302E
STRIPPER	
Round	415021
Square	415022
Rectangle	415023
Oblong	415024
O.D. Ground Special Shape	41502G
EDM Required Special Shape	41502E
DIE (HWS)	
Round	414021
Square	414022
Rectangle	414023
Oblong	414024
O.D. Ground Special Shape	41402G
EDM Required Special Shape	41402E

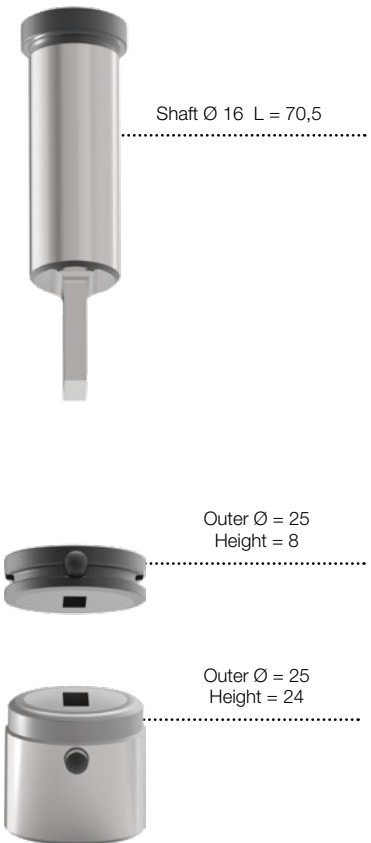

PUNCH OPTIONS

TICN coating (working with stainless steel)
 T-MAX coating (working with galvanised sheet / zincor)
 A-MAX coating (working with aluminum)
 WT-shear (whisper shear)
 DOWT-shear (rooftop shear)
 2 PT-shear (inverted rooftop shear)
 4 PT-shear (inverted cross shear)
 Cutting part under 1,00 mm

DIE OPTIONS

Reinforced die
 H-PM® Quality
 Additional pin hole

PRIMA POWER

MTPi8-24; MTP5-24; MT8-24

PART-NO.

Shaft Ø 24
L = 70,5



Outer Ø = 30
Height = 10,5



Outer Ø = 31
Height = 24



PUNCH (H-PM®)		PART-NO.
Round		413131
Square		413132
Rectangle		413133
Oblong		413134
O.D. Ground Special Shape		41313G
EDM Required Special Shape		41313E

STRIPPER		PART-NO.
Round		415131
Square		415132
Rectangle		415133
Oblong		415134
O.D. Ground Special Shape		41513G
EDM Required Special Shape		41513E

DIE (HWS)		PART-NO.
Round		414131
Square		414132
Rectangle		414133
Oblong		414134
O.D. Ground Special Shape		41413G
EDM Required Special Shape		41413E

PUNCH OPTIONS

- TICN coating (working with stainless steel)
- T-MAX coating (working with galvanised sheet / zincor)
- A-MAX coating (working with aluminum)
- WT-shear (whisper shear)
- DOWT-shear (rooftop shear)
- 2 PT-shear (inverted rooftop shear)
- 4 PT-shear (inverted cross shear)
- Cutting part under 1,00 mm

DIE OPTIONS

- Reinforced die
- H-PM® Quality
- Additional pin hole

PRIMA POWER

MT3Ri-31,75; MT3i-31,75

	PART-NO.
PUNCH (H-PM®)	
Round	413181
Square	413182
Rectangle	413183
Oblong	413184
O.D. Ground Special Shape	41318G
EDM Required Special Shape	41318E
STRIPPER	
Round	415181
Square	415182
Rectangle	415183
Oblong	415184
O.D. Ground Special Shape	41518G
EDM Required Special Shape	41518E
DIE (HWS)	
Round	414181
Square	414182
Rectangle	414183
Oblong	414184
O.D. Ground Special Shape	41418G
EDM Required Special Shape	41418E



PUNCH OPTIONS	DIE OPTIONS
---------------	-------------

- TICN coating (working with stainless steel)
- T-MAX coating (working with galvanised sheet / zincor)
- A-MAX coating (working with aluminum)
- WT-shear (whisper shear)
- DOWT-shear (rooftop shear)
- 2 PT-shear (inverted rooftop shear)
- 4 PT-shear (inverted cross shear)
- Cutting part under 1,00 mm

- Reinforced die
- H-PM® Quality
- Additional pin hole

PRIMA POWER

MT20i-8



PART-NO.

PUNCH (H-PM®)		
	Round	413111
	Square	413112
	Rectangle	413113
	Oblong	413114
	O.D. Ground Special Shape	41311G
	EDM Required Special Shape	41311E

STRIPPER		
	Round	415111
	Square	415112
	Rectangle	415113
	Oblong	415114
	O.D. Ground Special Shape	41511G
	EDM Required Special Shape	41511E

DIE (HWS)		
	Round	414111
	Square	414112
	Rectangle	414113
	Oblong	414114
	O.D. Ground Special Shape	41411G
	EDM Required Special Shape	41411E

PUNCH OPTIONS

- TICN coating (working with stainless steel)
- T-MAX coating (working with galvanised sheet / zincor)
- A-MAX coating (working with aluminum)
- WT-shear (whisper shear)
- DOWT-shear (rooftop shear)
- 2 PT-shear (inverted rooftop shear)
- 4 PT-shear (inverted cross shear)
- Cutting part under 1,00 mm

DIE OPTIONS

- Reinforced die
- H-PM® Quality
- Additional pin hole

PRIMA POWER

MT8Ri2-16 (VERSION 2)

	PART-NO.
PUNCH (H-PM®)	
Round	413151
Square	413152
Rectangle	413153
Oblong	413154
O.D. Ground Special Shape	41315G
EDM Required Special Shape	41315E
STRIPPER	
Round	415151
Square	415152
Rectangle	415153
Oblong	415154
O.D. Ground Special Shape	41515G
EDM Required Special Shape	41515E
DIE (HWS)	
Round	414151
Square	414152
Rectangle	414153
Oblong	414154
O.D. Ground Special Shape	41415G
EDM Required Special Shape	41415E



PUNCH OPTIONS	DIE OPTIONS
TICN coating (working with stainless steel)	Reinforced die
T-MAX coating (working with galvanised sheet / zincor)	H-PM® Quality
A-MAX coating (working with aluminum)	Additional pin hole
WT-shear (whisper shear)	
DOWT-shear (rooftop shear)	
2 PT-shear (inverted rooftop shear)	
4 PT-shear (inverted cross shear)	
Cutting part under 1,00 mm	

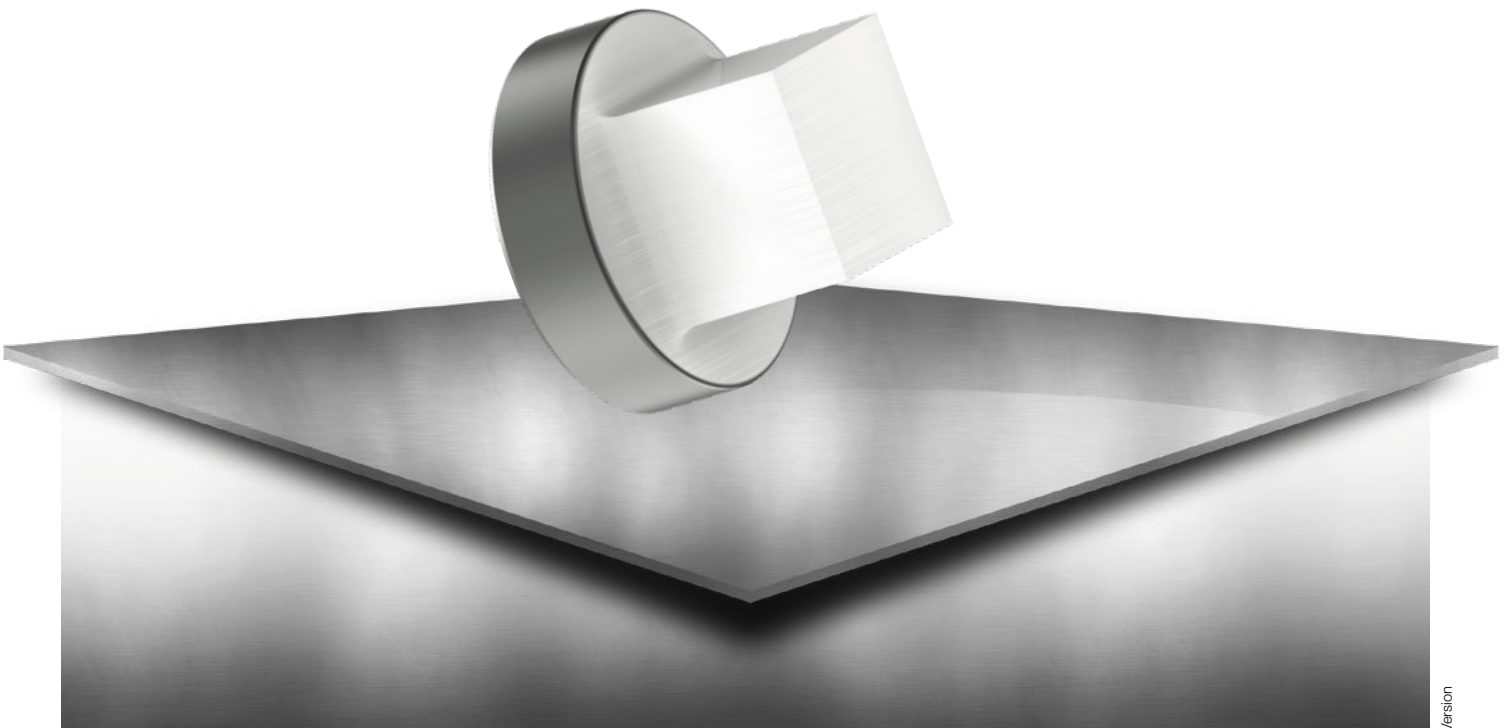

OPTIONS

PASS OPTIONS FOR YOUR PRIMA POWER MULTITOOL SYSTEM

INDEX

Draw-polishing

page 14

DRAW-POLISHING

PUNCH EDGES

INCREASES TOOL LIFETIME, REDUCES MATERIAL BUILD UP

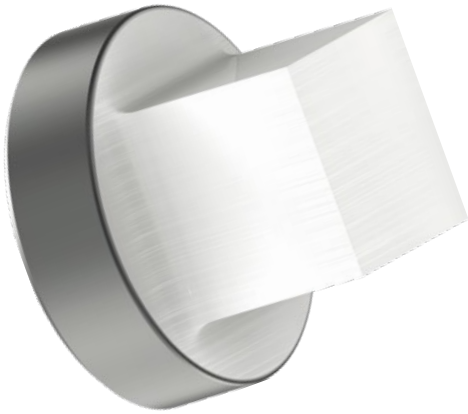

ROUND / SQUARE / RECTANGLE / OBLONG
for all multitools

O.D. GROUND SPECIAL SHAPES (SPECIAL SHAPE GROUP 1 & 2)
for all multitools

EDM REQUIRED SPECIAL SHAPES (SPECIAL SHAPE GROUP 3 & 4)
for all multitools

A large grid of graph paper for taking notes, consisting of 20 columns and 40 rows of small squares.



SPECIAL SHAPES

PASS SPECIAL SHAPES FOR YOUR PRIMA POWER /
MULTITOOL SYSTEM

INDEX

O.D. Ground Special Shapes	page 18
EDM Required Special Shapes	page 19

O.D. GROUND SPECIAL SHAPES

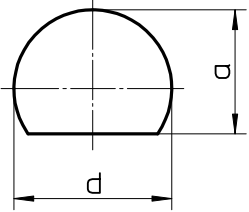
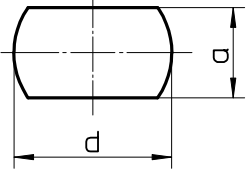
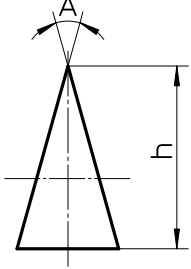
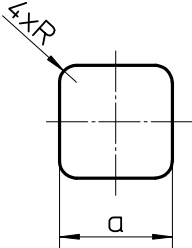
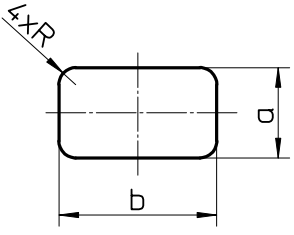
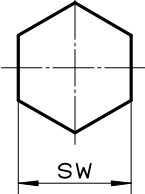
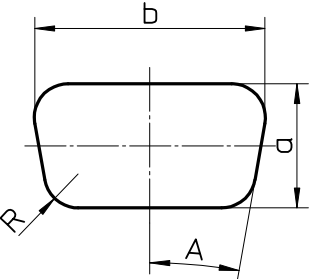
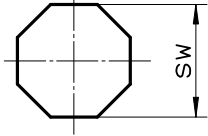
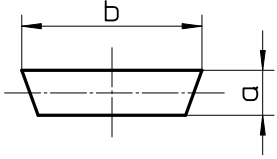
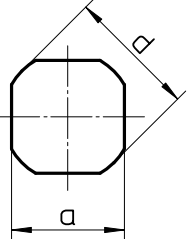
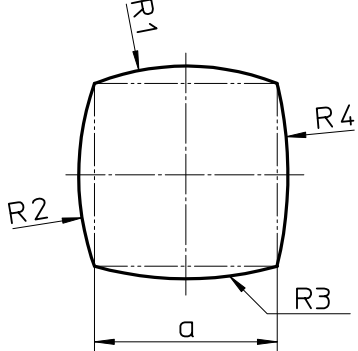
 <p>G01</p>	 <p>G02</p>	 <p>G03</p>
 <p>G04</p>	 <p>G05</p>	 <p>G06</p>
 <p>G07</p>	 <p>G08</p>	 <p>G09</p>
 <p>G10</p>	 <p>G11</p>	

EDM REQUIRED SPECIAL SHAPES

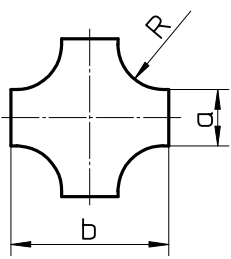
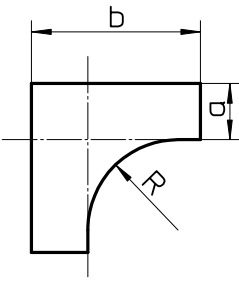
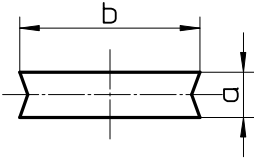
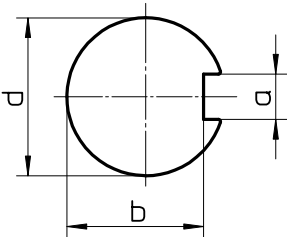
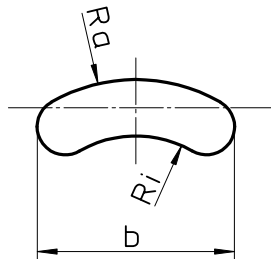
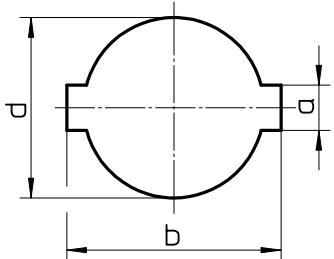
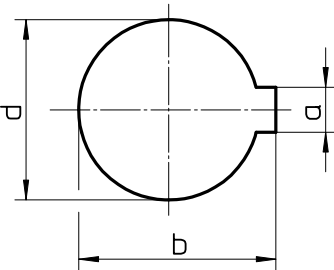
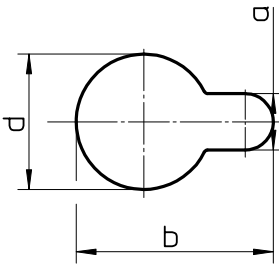
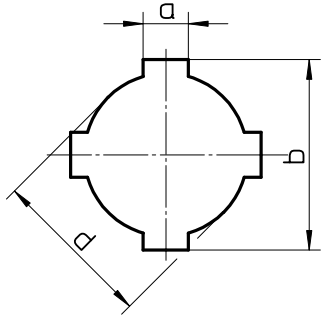
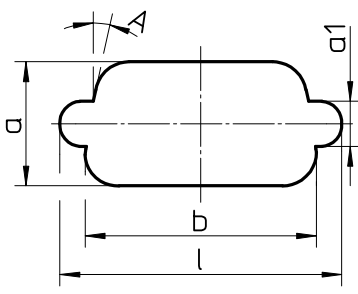
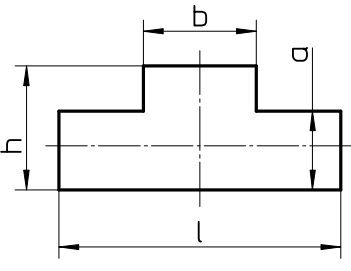
 <p>E01</p>	 <p>E02</p>	 <p>E03</p>
 <p>E04</p>	 <p>E05</p>	 <p>E06</p>
 <p>E07</p>	 <p>E08</p>	 <p>E09</p>
 <p>E10</p>	 <p>E11</p>	

SALVAGNINI | **THICK TURRET** | **TRUMPF**



Am Steinkreuz 2
95473 Creußen | Germany

WEB: www.pass-ag.com
MAIL: info@pass-ag.com

FON: +49 (0) 92 70 / 9 85 - 0
FAX: +49 (0) 92 70 / 9 85 - 99